

P	LTR	DESCRIPTION	DATE	DWN	APVD
A		INITIAL RELEASE	27MAY2020	AS	LH

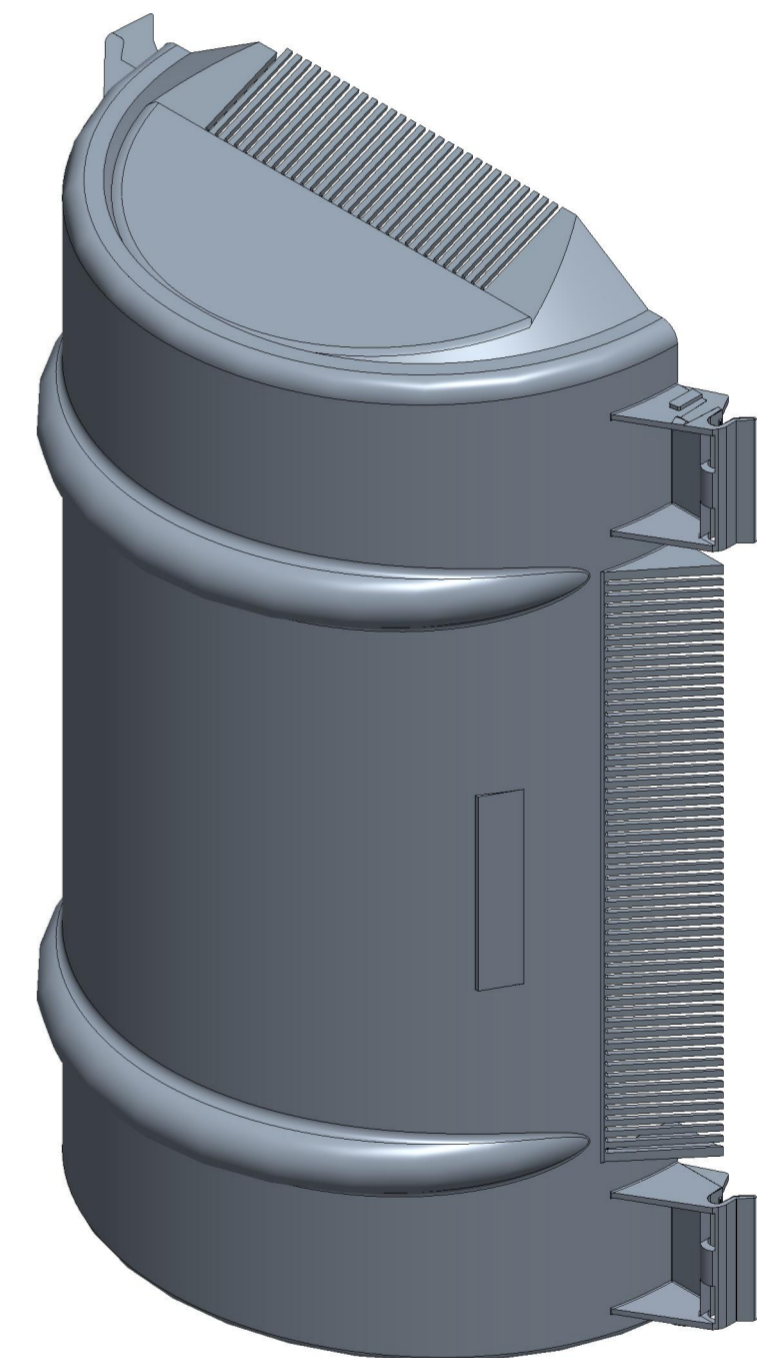
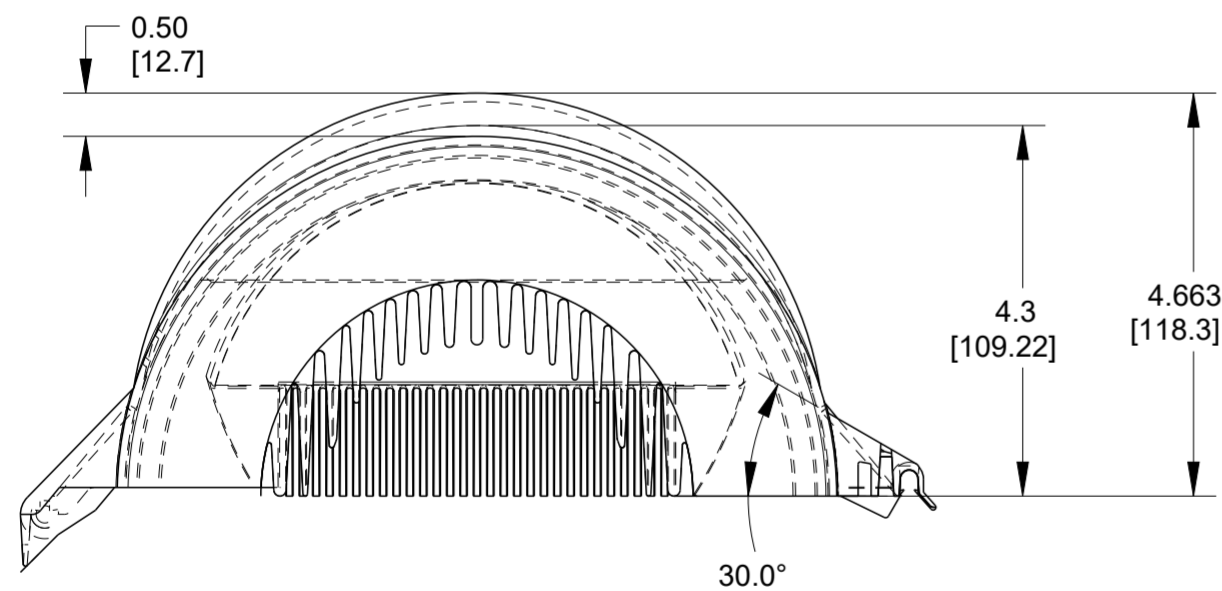
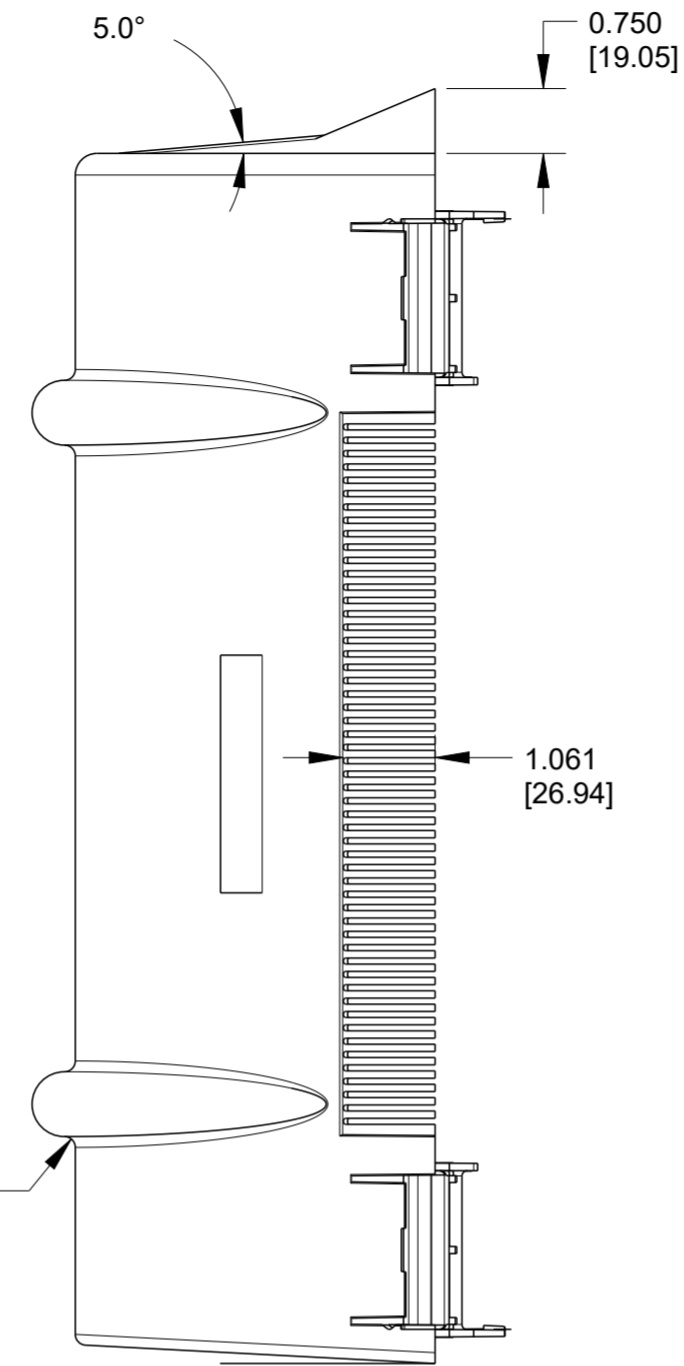
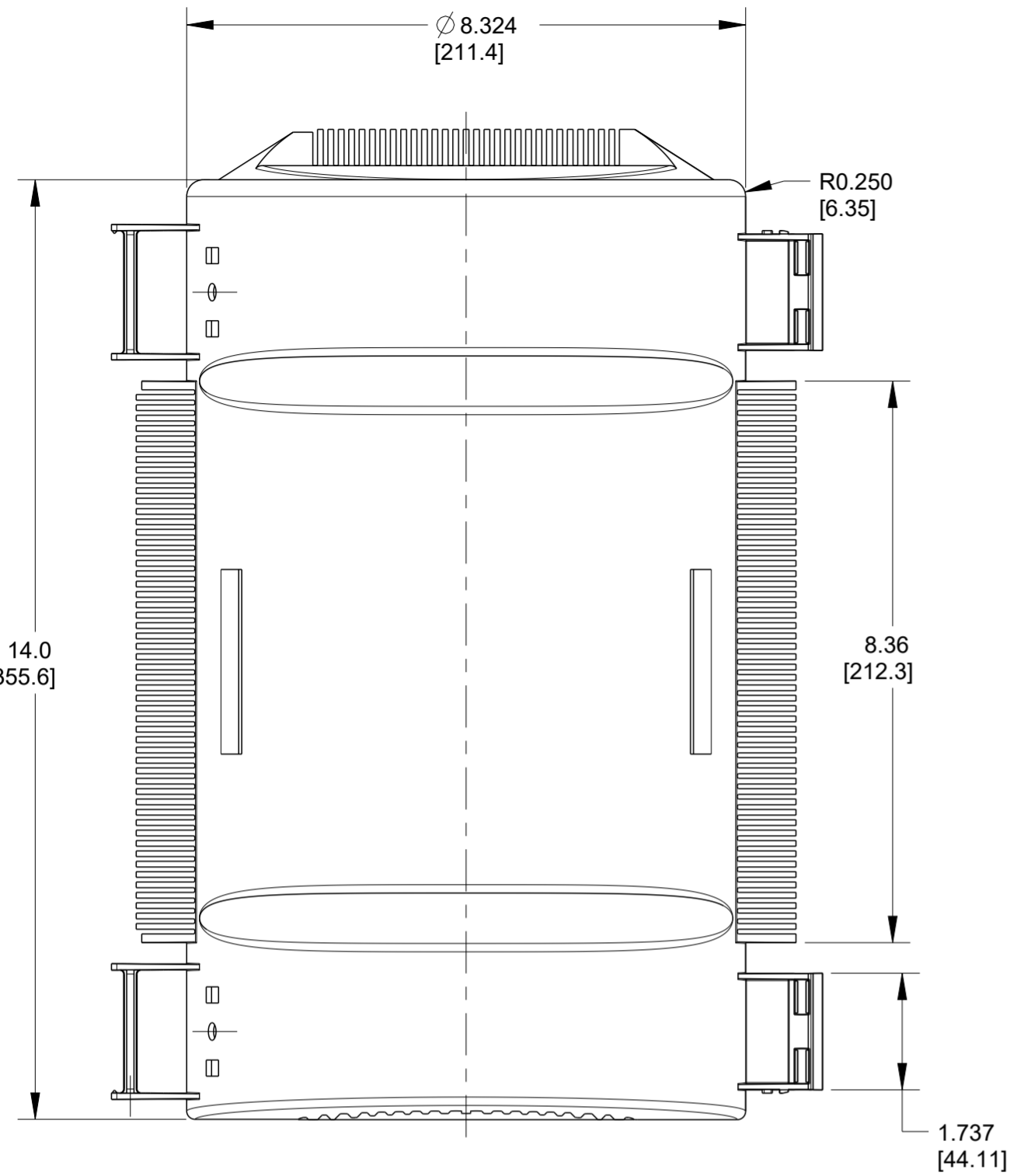

NOTES:

- PARTS SHALL BE KITTED WITH PII-55467 1 PC
- PARTS SHALL BE KITTED WITH 127252-000 BOLT-1/4-20X1/2-BLK-UV 12 PC
- PARTS SHALL BE KITTED WITH 218852-000 NUT-1/4-20-HEX-BLK-UVNYL 12 PC
- PARTS SHALL BE KITTED WITH C53932-000 BCAC-GA-01-A 12 PC,
- EACH KIT PACKED WITH 12 HALVES
- EACH BOX SHALL BE LABELLED WITH DESCRIPTION, LOT NUMBER, PART NUMBER, MANUFACTURING DATE AND QUANTITY.

TCPN	DESCRIPTION
D80266-000	BCAC-8D/14-01(B6)
C51711-000	BCAC-G-8D/14-01(B6)

THIS DRAWING IS A CONTROLLED DOCUMENT.		DWN A. SABARAD 27MAY2020		
DIMENSIONS: INCH(MM)		CHK S. LIGHT 27MAY2020		
TOLERANCES UNLESS OTHERWISE SPECIFIED:		APVD L. HILLER 27MAY2020	NAME BCAC-8D/14-01 BCAC-G-8D/14-012	
0 PLC ±		APPLICATION SPEC	SIZE	CAGE CODE
1 PLC ±		WEIGHT	A2	00779
2 PLC ±		CUSTOMER DRAWING	SCALE	NTS
3 PLC ±			SHEET	1 OF 1
4 PLC ±			REV	A
ANGLES ±				
FINISH				