

NOTES:

1. MATERIAL: TEPO-B (BLACK) 2±0.5 mm WALL THICKNESS.
2. ALL FILLETS/RADII 6mm UNLESS STATED OTHERWISE.
3. ALL TOLERANCES 3mm UNLESS STATED OTHERWISE.
4. ALL DRAFT ANGLES 3° UNLESS STATED OTHERWISE.
5. EACH PART EMBOSSED OR STAMPED AS SHOWN - MINIMUM LETTER HEIGHT 10mm.
6. 10 POLECAPS PACKED IN A SEALED POLYBAG.
7. SUPPLIED IN PACK OF 10 LABELLED WITH DESCRIPTION, PART NUMBER, BATCH NUMBER, MANUFACTURING DATE, WEIGHT AND QUANTITY.

MARKINGS:

PRODUCT DESCRIPTION (SEE TABLE)
 CAP No (SEE TABLE)
 FITS ØMIN-MAX (SEE TABLE)
 DATE CLOCK
 BATCH # CLOCK

TE LOGO

MATT FINISH ON TOP SURFACE FACE
 VDI 3400 FINISH BETWEEN 12 TO 15
 -EXCEPT FOR PRODUCT PRINT AREAS

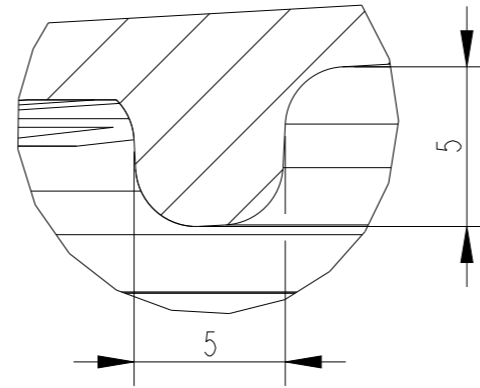

DETAIL A
 SCALE 4:1
 TYP 3 PLCS

REVISIONS					
P	LTR	DESCRIPTION	DATE	DWN	APVD
	A	INITIAL RELEASE	05JAN2024	BJ	IB
	AI	REVISED PER ECR-24-207704	18APR2024	MT	JM

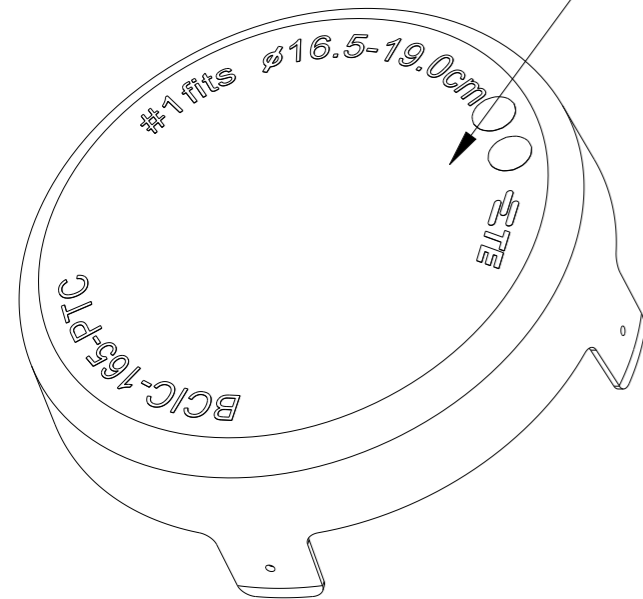

TCPN	DESCRIPTION	PRODUCT DESCRIPTION	DIM A (mm)	DIM (B) (mm)	CAP No	POLE TOP DIAMETER	
						MIN(cm)	MAX(cm)
ES4400-000	BCIC-165-PTC (B10)	BCIC-165-PTC	191	74.6	#1	16.5	19.0
ES4401-000	BCIC-191-PTC (B10)	BCIC-191-PTC	216	74.6	#2	19.1	21.5
ES4402-000	BCIC-216-PTC (B10)	BCIC-216-PTC	241	74.6	#3	21.6	24.0
ES4403-000	BCIC-241-PTC (B10)	BCIC-241-PTC	267	74.6	#4	24.1	26.6
ES4404-000	BCIC-267-PTC (B10)	BCIC-267-PTC	292	74.6	#5	26.7	29.1
ES4405-000	BCIC-292-PTC (B10)	BCIC-292-PTC	318	74.6	#6	29.2	31.7
ES4406-000	BCIC-318-PTC (B10)	BCIC-318-PTC	343	74.6	#7	31.8	34.2
ES4407-000	BCIC-343-PTC (B10)	BCIC-343-PTC	368	74.6	#8	34.3	36.7
ES4408-000	BCIC-368-PTC (B10)	BCIC-368-PTC	394	74.6	#9	36.8	39.3

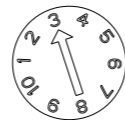

DATE CLOCK BATCH # CLOCK
 SCALE 1:1

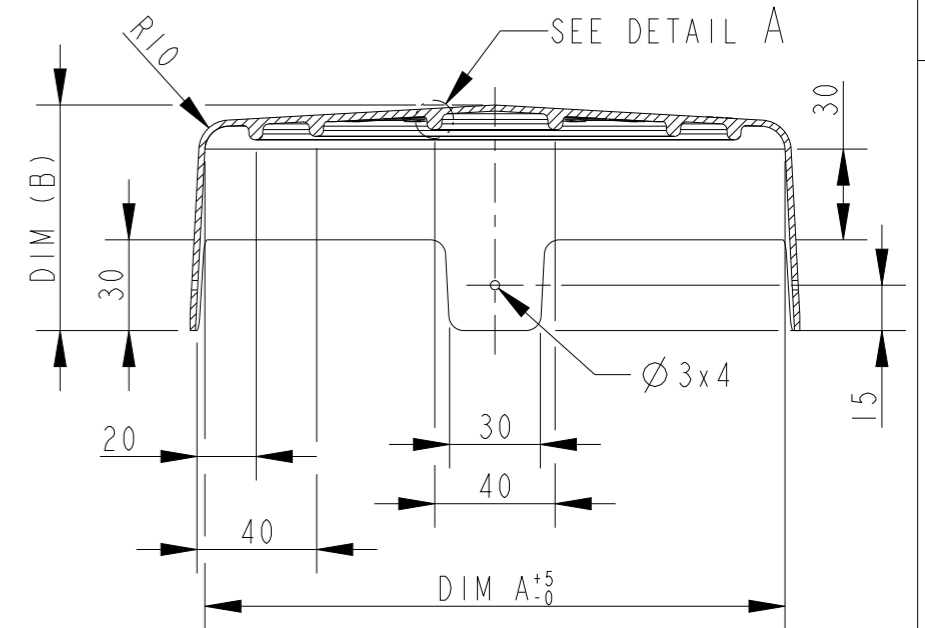
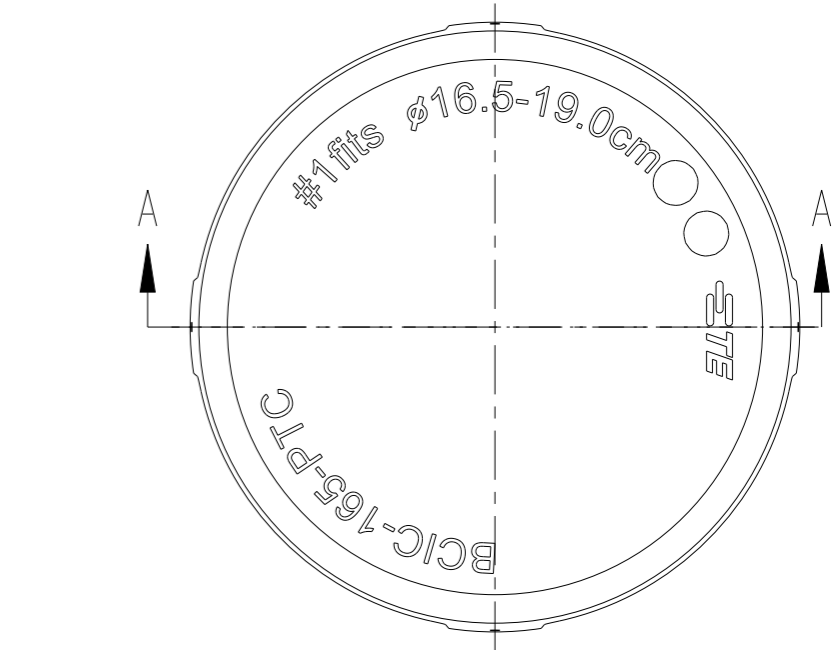
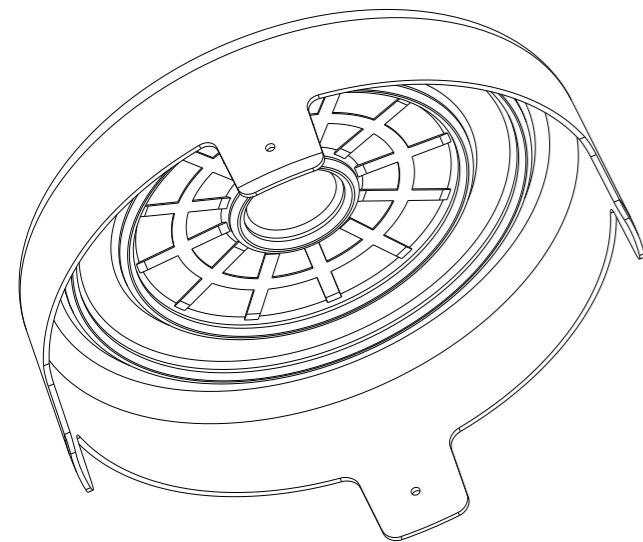

SECTION A-A

THIS DRAWING IS A CONTROLLED DOCUMENT.		DWN B JOEL 29MAY2023	TE Connectivity NAME BCIC-xxx-PTC (B10) SEE TABLE			
DIMENSIONS: mm		CHK M JAMES 29MAY2023				
TOLERANCES UNLESS OTHERWISE SPECIFIED:		APVD I BOND 29MAY2023				
0 PLC ± 1 PLC ± 2 PLC ± 3 PLC ± 4 PLC ± ANGLES ± FINISH -		PRODUCT SPEC -				
MATERIAL SEE NOTES		APPLICATION SPEC -	SIZE A3	CAGE CODE 00779	DRAWING NO C-WAP-BCIC-0123-C	RESTRICTED TO -
CUSTOMER DRAWING			SCALE 1:3	SHEET 1 OF 1	REV AI	